

Suspe Directional

NOTES:

a
 EXTRUSION finish/color options:
 are made from high quality aluminum 6063 with an anodized or oven cured coating
 1. Clear anodized aluminum

b
 INSERT OPTIONS:
 1. Graphic sign fronts:
 engraved, laminated, silk screened, Imprinted with braille or photo metal finished
 2. Applied vinyl on aluminum insert
 3. 1. .040 aluminum backed photopolymer w/ raised symbols/copy and ADA compliant braille. Tip symbols/copy to contrast background Braille to remain background color
 4. Acrylic cover w/ paper insert
 5. Digital printing onto anodized aluminum by Primodize® or direct on clear cover

PANELS
 1. Plastic divider black or silver with strips of clear cover
 2. Natural or anodized alum strips

c
 END CAPS finish/color options:
 1. Clear anodized aluminum
 2. Can be painted or powder coated
 3. Gray or black ABS plastic
 4. Clear anodized aluminum base

d
 ACCENT BAR (available page no.*)
 finish/color options:
 1. Standard Mirtec anodized colors
 2. Can be painted or powder coated

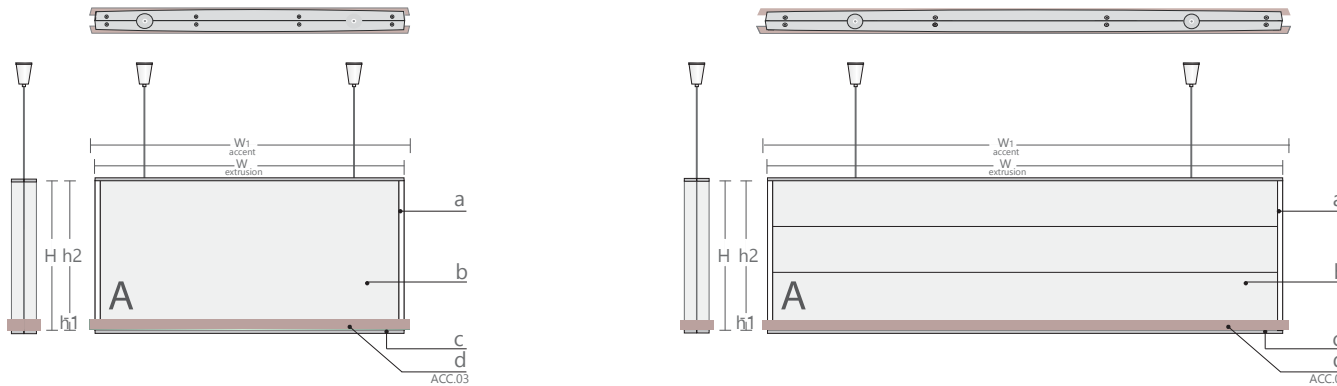

Standard sizes		A		AA		AAA	
No.	Part No.	H x W		H x W		H x W	
		mm	inch	mm	inch	mm	inch
1	Mir2161- Acc.00	203 x <u>304</u>	10 x <u>11.9</u>	305 x <u>304</u>	12 x <u>11.9</u>	406 x <u>304</u>	16 x <u>11.9</u>
2	Mir2162- Acc.00	305 x <u>404</u>	12 x <u>15.9</u>	406 x <u>404</u>	16x <u>15.9</u>	610 x <u>404</u>	24 x <u>15.9</u>
3	Mir2299- Acc.00	305 x <u>436</u>	11 x <u>17</u>	432 x <u>436</u>	17 x <u>17</u>	610 x <u>436</u>	24 x <u>17</u>
4	Mir2163- Acc.00	355 x <u>504</u>	17 x <u>19.8</u>	508 x <u>504</u>	20 x <u>19.8</u>	762 x <u>504</u>	30 x <u>19.8</u>
5	Mir2164- Acc.00	406 x <u>604</u>	20 x <u>23.7</u>	610 x <u>604</u>	24 x <u>23.7</u>	838 x <u>604</u>	33 x <u>23.7</u>

1. Select the size of the sign from **Extrusion Standard sizes** table.
2. Select an accent from the **Accent Bar Sizes** table.
3. Matche the accent size to the sign size. The sizes are underlined in both tables
4. Select the Accent location on the sign frame parallel to the location of the end caps.

Accent Bar Sizes

No.	Accent	Accent -H1		Extrusion	Extrusion	Extrusion	Extrusion	Extrusion	Extrusion	Extrusion	Extrusion	Extrusion	Extrusion
		mm	inch	W1	W1	W1	W1	W1	W1	W1	W1	W1	W1
1	Acc.03	13	0.51	W1 315mm/12.4"	W1 415mm/16.3"	W1 447mm/17.5"	W1 515mm/20.2"	W1 615mm/24.2"	W1 715mm/28.1"	W1 815mm/32.1"	W1 915mm/36"	W1 1015mm/39.9"	W1 1115mm/44.3"
2	Acc.04	20	0.79	W1 315mm/12.4"	W1 415mm/16.3"	W1 447mm/17.5"	W1 515mm/20.2"	W1 615mm/24.2"	W1 715mm/28.1"	W1 815mm/32.1"	W1 915mm/36"	W1 1015mm/39.9"	W1 1115mm/44.3"
3	Acc.05	40	1.57	W1 315mm/12.4"	W1 415mm/16.3"	W1 447mm/17.5"	W1 515mm/20.2"	W1 615mm/24.2"	W1 715mm/28.1"	W1 815mm/32.1"	W1 915mm/36"	W1 1015mm/39.9"	W1 1115mm/44.3"

5.0

